

# HIGH RATE SERIES



## UPS12-100

**VALVE REGULATED  
LEAD ACID BATTERY  
FOR UPS STANDBY  
POWER APPLICATIONS  
12V 26 AH @ 20 HR RATE,  
12V 91 WATTS/CELL  
@ 15 MIN. RATE**

### FEATURES

- 10 Year design life @ 25°C (77°F)
- Absorbent Glass Mat (AGM) technology for efficient gas recombination of up to 99% and freedom from electrolyte maintenance.
- Patented flame-arresting one-way pressure-relief valve providing vacuum and controlled backpressure for long life recombinant operation.
- Designed to comply with ANSI and Eurobat battery standards.
- Specifically designed for optimum performance in UPS applications.
- Proprietary computer modeled radial grid matrix using multiple conductors for providing the lowest internal resistance and highest current carrying efficiency.
- Proprietary Fixed Orifice Pasting technology applying active material on both sides of the grid for consistent cell-to-cell performance, highest paste packing efficiency and uniform grid protection.
- Lowest calcium levels among battery manufacturers minimizing grid growth and extending battery life.
- UL-recognized component.
- Thermally welded case-to-cover bond to eliminate leakage.
- Can be mounted in any orientation. Upright, side or end mounting recommended.
- Not restricted for air transport – Complies with IATA/ICAO Special Provision A67.
- Not restricted for surface transport – Classified as non-hazardous material as related to DOT-CFR Title 49 parts 171-189.
- Flame retardant polypropylene case and cover compliant with UL 1778 (optional).

**12 Volts – 91 Watts Per Cell For 15 Minutes to 1.67 Volts per Cell**

Constant Power Discharge Ratings – Watts Per Cell @ 77°F (25°C)

End Point Volts/Cell	Operating Time to End Point Voltage (in minutes)									
	5	10	15	20	30	40	45	50	60	90
1.67	172	117	91	75	57	47	43	39	34	25

C&D Technologies, Inc.  
DYNASTY Division  
900 East Keefe Avenue  
Milwaukee, WI 53212  
Phone: 800-396-2789  
Fax: 414-961-6506



# UPS12-100

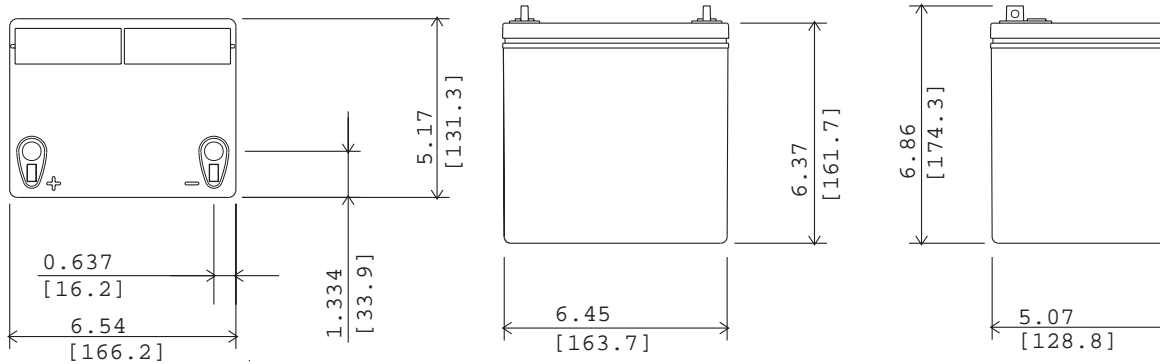

## UPS12-100 – Specifications

\*All dimensions in inches and (millimeters). All dimensions are for reference only. Contact a C&D Representative for complete dimensional information.

Cells Per Unit	Voltage Per Unit	Weight	Electrolyte	Maximum Discharge Current	Short Circuit Current	Ohms Imped. 60 Hz (w)
6	12.84	21 lbs. 10 kg	Absorbed H <sub>2</sub> SO <sub>4</sub> SG = 1.300	500 Amps	1750 Amps @ 0.1 sec.	0.0060 Ohms
<b>Capacity</b>		91.0 watts per cell at the 15 minute rate to 1.67 volts per cell at 77° F (25° C). 26.0 Ah @ 20 hr. rate to 1.75 volts per cell @ 77° F (25° C) 23.6 Ah @ 10 hr. rate to 1.80 volts per cell @ 20° C (68° F)				
<b>Operating Temperature Range</b>		<b>Discharge;</b> -40° F (-40° C) to +160° F (71° C), <b>Charge;</b> -10° F (-23° C) to +140° F (60° C) (with temperature compensation)				
<b>Nominal Operating Temperature Range</b>		+74° F (23° C) to +80° F (27° C)				
<b>Float Charging Voltage</b>		13.5 to 13.8 VDC/unit Average at 77° F (25° C).				
<b>Recommended Maximum Charging Current Limit</b>		C/5 amperes (5.2 amperes @ 100% depth of discharge) @ 20 hour rate				
<b>Equalization and Cycle Service Charging Voltage</b>		14.4 to 14.8 VDC/unit Average at 77° F (25° C).				
<b>Maximum AC Ripple (Charger)</b>		0.5% RMS or 1.5% P-P of float charge voltage recommended for best results. Maximum voltage allowed = 1.4% RMS (4% P-P) Maximum current allowed = 1.3 amperes RMS (C/20)				
<b>Self Discharge</b>		Dynasty UPS batteries may be stored for up to 6 months at 77° F (25° C) and then a freshening charge is required. For higher temperatures the time interval will be shorter.				
<b>Accessories</b>		Inter unit connectors, racks and cabinet systems are available.				
<b>Terminal</b>		Flag terminal with 0.22" clearance hole to accept 0.1875" bolt.				
<b>Terminal Hardware Initial Torque</b>		40 in.-lbs. (4.5 N-m).				
<b>Terminal Hardware Annual Retorque</b>		32 in.-lbs. (3.48 N-m).				

## Constant Power Discharge Ratings – Watts Per Cell @ 77°F (25°C)

Operating Time to End Point Voltage (in minutes)

End Point Volts/Cell	5	10	15	20	30	40	45	50	60	90
1.75	158	111	88	73	56.0	45.6	41.9	38.6	33.4	24.2
1.70	168	115	90	74	56.5	45.9	42.2	39.0	33.7	24.4
1.67	172	117	91	75	57.0	46.5	42.6	39.5	34.3	24.5
1.65	174	118	92	76	57.4	46.9	43.0	39.8	34.5	24.8
1.60	179	119	92	77	58.1	47.3	43.4	40.1	34.9	25.0

## Constant Current Discharge Ratings – Amperes @ 77°F (25°C)

Operating Time to End Point Voltage (in hours)

End Point Volts/Cell	.083	.25	.50	.75	1	2	3	5	8	10	12	20	24	72	100
1.90	51.1	33.0	22.4	17.1	13.8	8.30	6.05	3.94	2.62	2.14	1.82	1.15	0.96	0.34	0.25
1.85	62.8	38.4	25.2	18.6	15.0	9.00	6.60	4.29	2.85	2.33	1.98	1.24	1.05	0.36	0.27
1.80	72.3	42.1	27.1	20.3	16.2	9.40	6.86	4.45	2.95	2.41	2.05	1.28	1.08	0.37	0.28
1.75	85.6	45.7	28.8	21.4	17.0	9.75	7.00	4.53	3.00	2.45	2.08	1.30	1.10	0.38	0.28

**Note:** Batteries to be mounted with 0.5 in (1.25 cm) spacing minimum and free air ventilation. Specifications subject to change without notification.